

SONIC 2022 MOUNT

Features:

- Easy to assemble lightweight design
- Made from coated 6061 aluminum
- Class 150 4" pipe flange face
- Hydrodynamic fairing
- Protective fin
- SVP mount inside fairing for protection
- Zinc anode
- Competitive priced
- Produced in EU
- Proven design

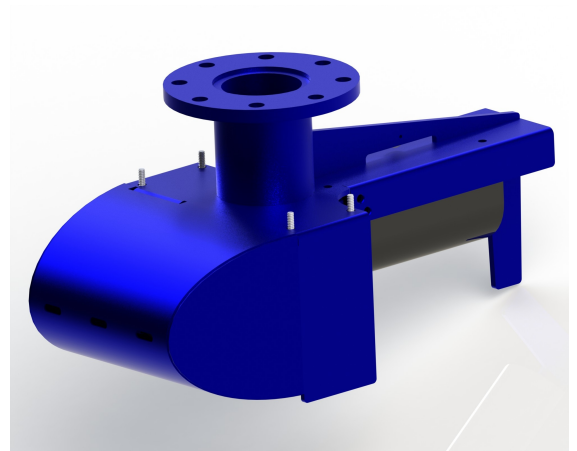

Description:

This Sonic 2024 mount is designed to get the best performance possible from the sonar system. It is lightweight and very easy to assemble. The mounting flange fits a class 150 4" mounting flange face.

The efficient fairing design minimize the drag and cavitation and protects the sound velocity probe witch is mounted inside. Water intake and ventilation holes ensures an efficient water flow over the SVP to ensure correct sound velocity readings.

All cables can be routed inside the flange to protect the cables. In some installations it may be necessary to run the cables outside the flange, which this design is prepared for as well.

The mount with the Sonic 2022 mounted can safely be stored on a flat surface without damaging the sonar heads.

Please see page 2 for outline dimension and acoustic center of the Sonic 2022.

Please contact C4R for further information.

SONIC 2022 MOUNT

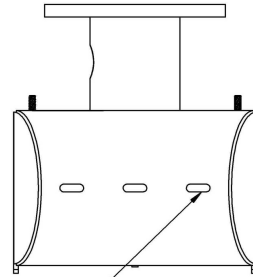

VENT HOLES TO ENSURE WATERFLOW TO SVP

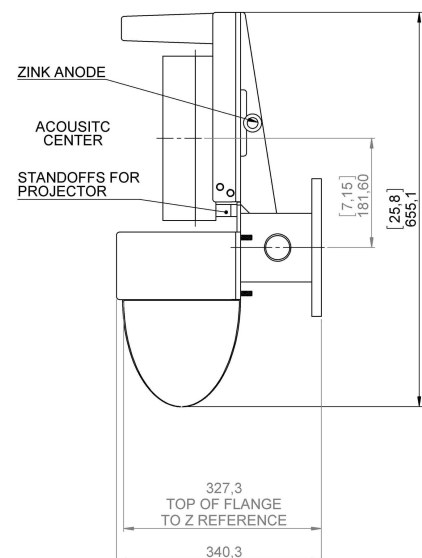
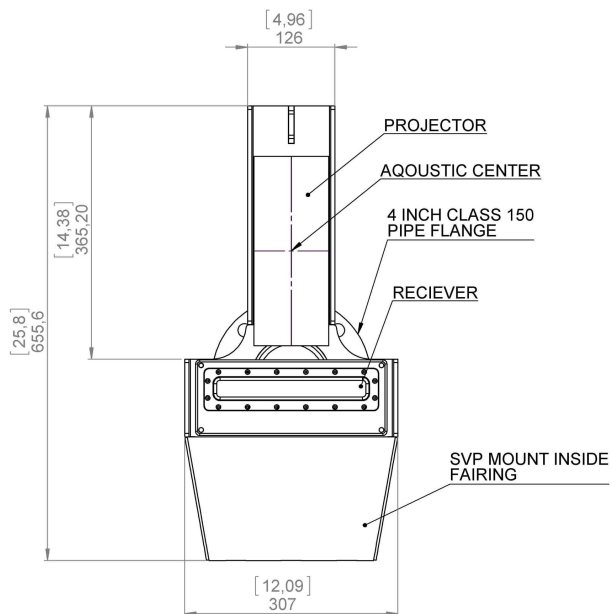
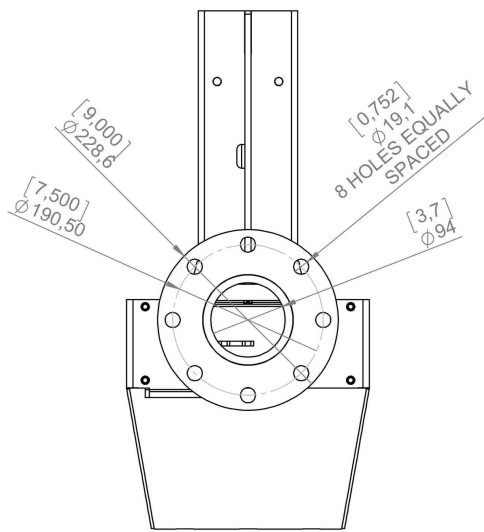

C4R
 Bill Endersen
 Senior Consultant
 Ellehammervej 17
 3600 Frederikssund
 Denmark
 +45-40550301
 mail@c4r.dk